



B&W Trailer Hitches
 1216 HWY 224 / PO Box 186
 Humboldt, KS 66748
 P:620.473.3664
 F:620.473.3766

NOTE: *We recommend reading instructions before beginning the installation.*

WARNING: *The tow vehicle's towing capacities should Under NO Circumstances be exceeded.*

Turnoverball™ Gooseneck Hitch Installation Instructions

Model 1307

Dodge 2006 - 2012

1/2, 3/4, & 1 Ton Mega Cab Short Bed
 and 2010-2012 Long and
 Short Bed with gas engine.

Call or Email us for Instalation Support

hitches@turnoverball.com www.turnoverball.com

HARDWARE KIT

- 11 - 1/2" X 1 1/2" Hex Cap Screws
- 9 - 1/2" Hex Finish Nuts
- 15 - 1/2" Split Lock Washers
- 11 - 1/2" Flat Washers
- 2 - 4" X 6 1/2" U-Bolts
- 2 - 5/8" X 7 1/2" Hex Cap Screws
- 2 - 5/8" Hex Finish Nuts
- 2 - 5/8" Split Lock Washers
- 2 - 5/8" Flat Washers
- 1 - 3/16" X 1" Carriage Bolt
- 1 - 5/16" Flange Nut

SAFETY CHAIN KIT

- 2 - 1/2" U-Bolts
- 4 - 1/2" Lock Nuts
- 4 - Conical Springs
- 1 - 3/8" X 3/4" Hex Cap Screw
- 1 - 3/8" Lock Nut

PARTS LIST

- 1 - Front Cross Member
- 2 - Rear Cross Member
- 3 - Center Section
- 4 - Left Side Plate
- 5 - Right Side Plate
- 6 - 4" X 6 1/2" U-Bolt
- 7 - 5/8" X 7 1/2" Hex Cap Screw
- 8 - 1/2" X 1 1/2" X 3/8" U-Bolt
- 9 - Tapered Spring
- 10 - 1/2" Center Lock Nut
- 11 - 5/8" Flat Washer
- 12 - 5/8" Split Lock Washer
- 13 - 5/8" Hex Finish Nut
- 14 - Latch Pin Handle
- 15 - 2-5/16" Ball

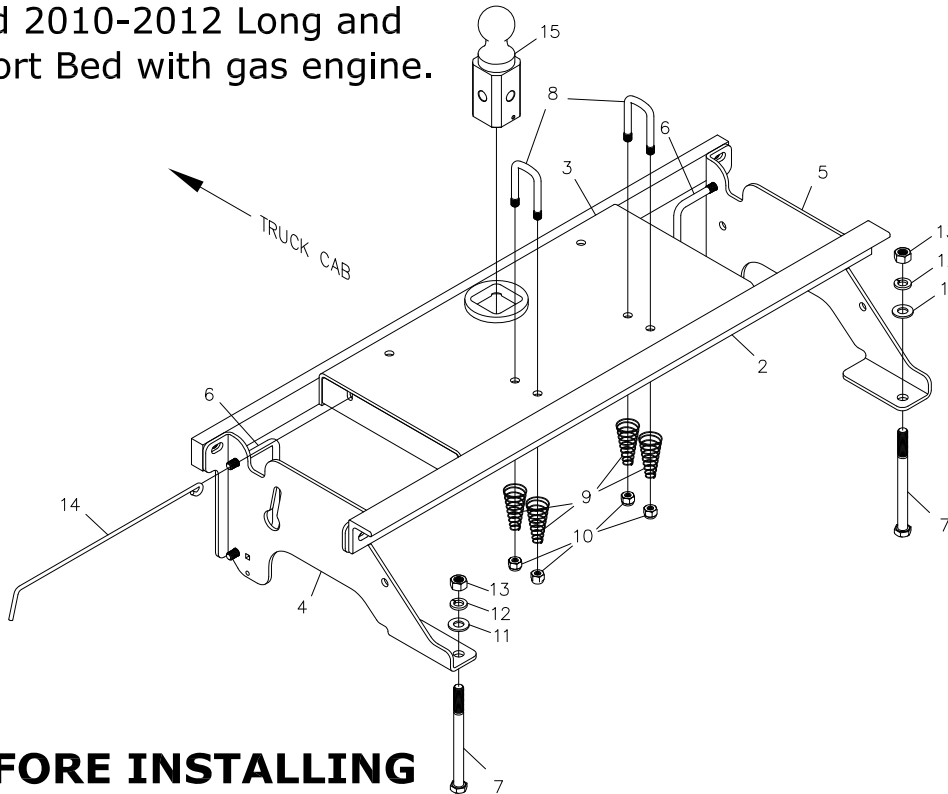

BEFORE INSTALLING

OVERHEAD LIFTING DEVICE

An overhead-lifting device, such as chain falls, engine hoist, or cable come-a-long, can be used to lift the center section of the hitch in place. Lower a loop of rope or chain through the 4" hole in the truck bed floor and attach it to the latch pin in the round hitch receiver tube in the center section. Use the lifting device to raise the center section until the round hitch receiver tube that protrudes from the center section fits in the 4" hole in the truck bed floor. Maintaining upward pressure may facilitate fastening the cross members to the center section, especially if the truck bed floor has been distorted downward from heavy use. If you use an overhead-lifting device, it should be disconnected before squaring the center section across the frame, installing the sideplates and torquing fasteners.

WARNING

Most trucks have FUEL LINES and/or BRAKE LINES and/or ELECTRICAL WIRES located along the frame rails where B&W Turnoverball™ hitches install. Carefully examine the location of fuel lines, brake lines and electrical wires BEFORE INSTALLATION. Be certain you will not damage fuel lines, brake lines or electrical wires when positioning hitch components, drilling holes, or tightening fasteners. The fuel tank vent, located on top of the gas tank, can be easily damaged during the installation of the hitch components. Care must be taken when positioning the front crossmember and center section components.

WARNING

TURNING CLEARANCE BETWEEN MOST GOOSENECK TRAILERS AND MEGACAB PICKUPS IS LIMITED. BEFORE INSTALLING THIS HITCH, CHECK FOR ADEQUATE TURNING CLEARANCE BETWEEN THE FRONT OF ALL OF YOUR TRAILERS AND THE TRUCK CAB.

WARNING

DO not invert the ball in the socket when carrying heavy loads on 2 wheel drive trucks. The ball may hit the top of the differential. Remove the ball from the socket before loading. A plug for the socket is available from B & W.

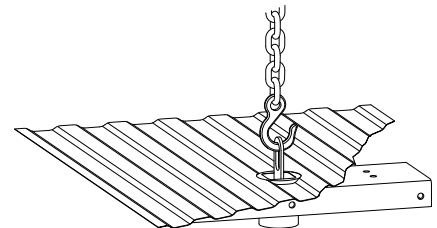

GENERAL INFORMATION

Megacab pickups have a tubular frame, instead of the traditional "C" shaped channel frame. The Turnoverball™ gooseneck hitch for this truck clamps to the frame and installation is accomplished without any welding, drilling, or modification of the truck frame.

INSTALLATION INSTRUCTIONS

STEP 1:

Begin by marking the location for the hole in the truck bed floor. Measure from the back end (tail gate end) of the truck bed floor by hooking a tape measure over the back of the truck box and mark the floor at the correct location. Next, mark the center between the wheel wells. This will be the center point for the 4" hole. This location is critical to the correct installation of this hitch, so measure, mark, and saw carefully.

BALL LOCATION:

SHORT BED INSTALLATION

45 1/2"

LONG BED INSTALLATION

47 1/2"

NOTE:

If the truck has a plastic bed liner, you may drill through both, but it is more difficult to accurately locate the midpoint between the wheel wells, and to be sure that the bed liner does not move while sawing the hole. Make a 4 inch hole at this location using a four inch hole saw, or by marking a 4 inch circle and cutting it out with a saber saw equipped with a metal cutting blade.

STEP 2:

Install the two cross members. They will be installed by sliding them from inside the wheel well, above the tire, through the gap between the bed and the truck's frame and across until they span the frame rails. The gap between the bed and frame is large enough to allow this, but the gap is partially obstructed by a sheet metal flange (about 1 inch in height) that is hanging down from the bottom of the truck bed floor. A small notch needs to be made in this flange on the Passenger's side of the truck. Locate the 7/16" hole in this flange above the axle, see figure 2.1, and enlarge the hole by removing the metal below the hole so that a notch is created, See figure 2.2 & 2.3. This will allow the rear cross member to be installed.

FIGURE 1.1

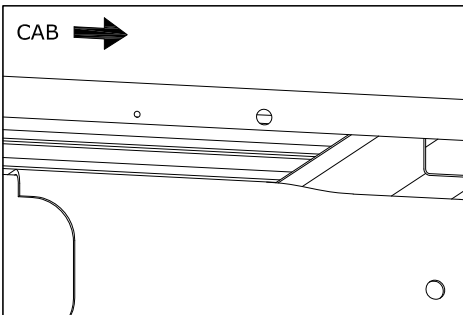
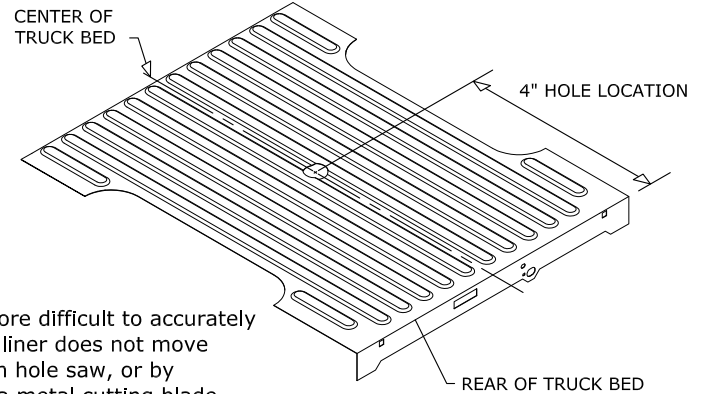

FIGURE 2.1: Hole location in passenger side wheel well.

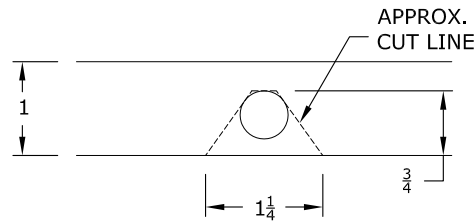

FIGURE 2.2

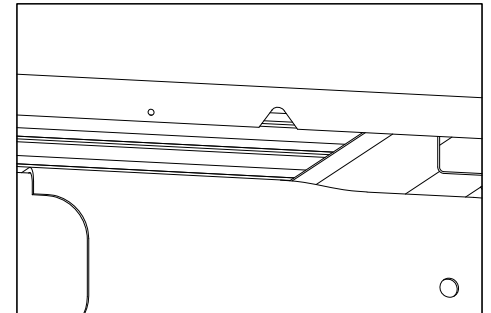

FIGURE 2.3: Flange with V-cut In Passenger side wheel well.

Slide the front cross member across the frame rails, See figure 2.4. Rotate cross member so that the holes on the end of the cross member are closest to the floor of the bed. Push cross member against bed cross member, See figure 2.5. Using the notch for clearance install the rear cross member with the angle oriented so that the leg with the slotted holes is facing the front of the truck, See figure 2.6. Hold the rear cross member in an inverted V position, and push the angle across the frame. Slide the cross member toward the rear of the truck so that there is approximately 14 inches between both cross members. Then rotate the cross member so that the leg with the slotted holes is vertical, See figure 2.7.

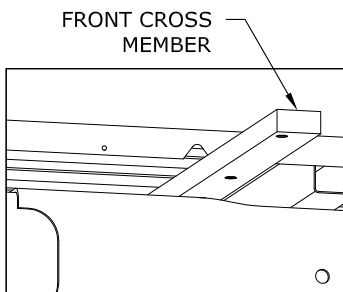

FIGURE 2.4: Front Cross Member

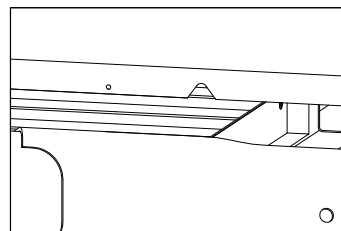

FIGURE 2.5: Installed Front Cross Member

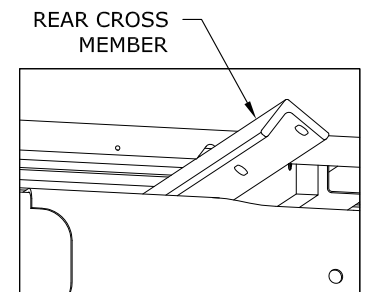

FIGURE 2.6: Rear Cross member

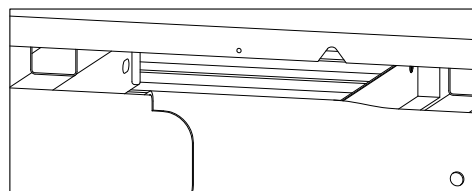

FIGURE 2.7: Installed Cross members

STEP 3:

Install the center section with the latch pin on the driver's side. Raise the center section over the differential while sliding the center section over the exhaust and guiding the socket top into the 4" hole in the truck bed floor. Move rear cross member forward against the center section. Place a 1/2" flat washer on a 1/2" X 1 1/2" hex cap screw. Insert the cap screw through the rear cross member and center section, securing it with a 1/2" lock washer, and a 1/2" finish nut. Thread a 1/2" X 1 1/2" hex cap screw with a 1/2" lock washer and a 1/2" flat washer into the front cross member from the inside of the center section. (DO NOT TIGHTEN AT THIS TIME)

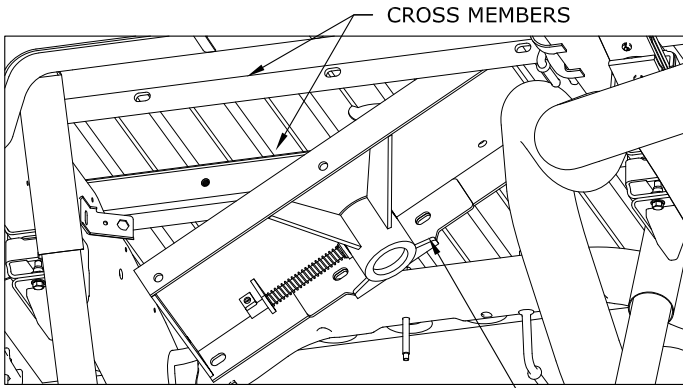

FIGURE 3.1: View under bed looking at area above axle.

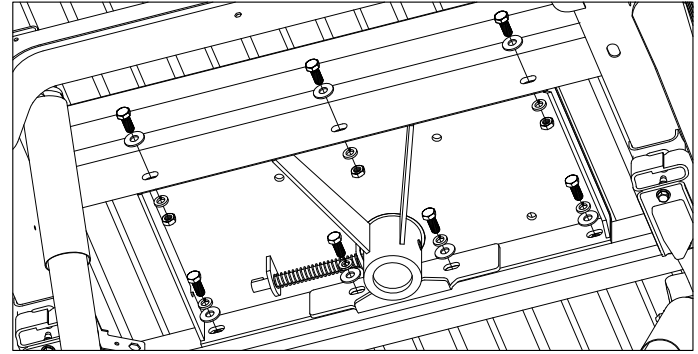

FIGURE 3.2: View under bed of hardware assembly.

STEP 4:

On some models, the emergency brake cable bracket on the driver side frame rail will need to be relocated. If the bracket is located between the two hitch cross members, remove the bracket and set it aside. The bracket will be relocated after the side plates are installed.

Next, install the U-bolts from inside the frame. To install the U-bolt on the driver's side it is necessary to remove a wiring harness frame clip, See figure 4.1. Place the U-bolt against the frame staying under the wiring harness, and brake line. While making certain that nothing is between the frame and U-bolt, raise the U-bolt until the top leg is level with the top of the frame rail. Then turn the legs toward to the outside so that the U-bolt straddles the frame. Replace the wiring harness frame clip, See figure 4.2. Place the U-bolt on the passenger side frame just behind the front hitch cross member.

Install the side plates on each side of the frame. Fit side plates over the legs of the U-bolt and fasten with a 1/2" lock washer and a 1/2" finish nut, See figure 4.3. Place a 1/2" X 1 1/2" hex cap screw, a 1/2" split lock washer, and a 1/2" flat washer through the side plate into the front cross member. With a 1/2" flat washer on a 1/2" X 1 1/2" hex cap screw. Insert the cap screw through the rear cross member and side plate, securing it with a 1/2" lock washer, and a 1/2" finish nut, See Figure 4.4.

Insert the 5/8" X 7 1/2" hex cap screw through the hole in the side plate that wraps underneath the frame. Push the hex cap screw completely through the frame and secure with a 5/8" flat washer, 5/8" lock washer, and 5/8" hex finish nut, See Figure 4.5. When installing the 5/8" X 7 1/2" hex cap screw on the passenger side the exhaust may need to be pulled to the side to allow the cap screw to pass by.

If the emergency brake cable bracket was removed at the beginning of this step relocate it onto the drivers side plate. Place a 5/16" X 1" carriage bolt through the side plate with the threads facing out. Next place the brake cable bracket over the carriage bolt and secure with a 5/16" flange nut, See Figure 4.6.

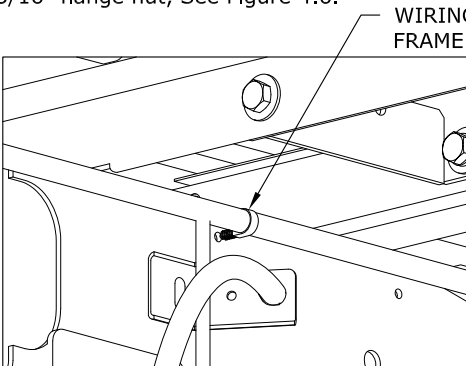

FIGURE 4.1: View under bed looking at driver side frame.

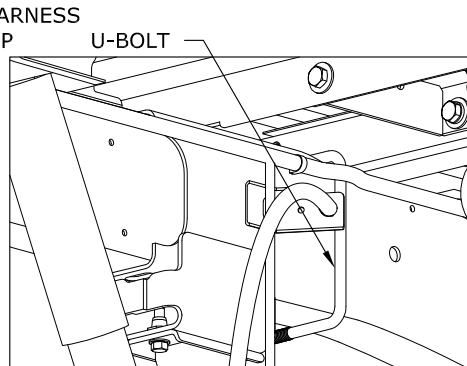

FIGURE 4.2: View under bed looking at driver side frame.

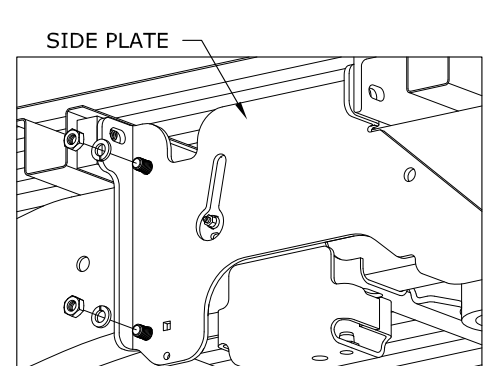

FIGURE 4.3: Side plate & U-Bolt on driver side of frame.

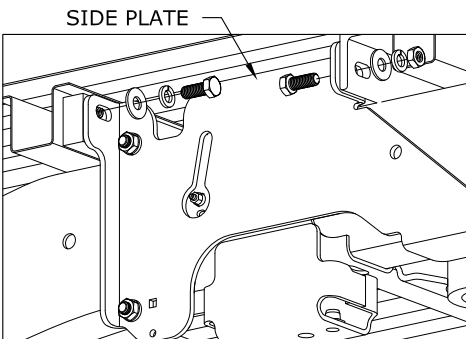

FIGURE 4.4: Driver side of frame.

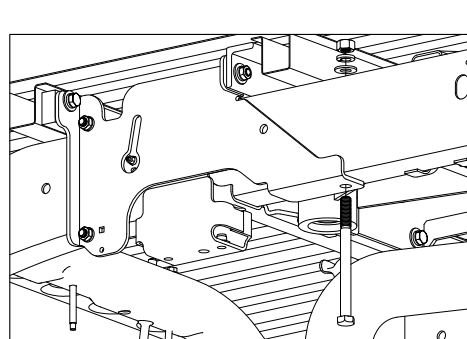

FIGURE 4.5: Driver side of frame.

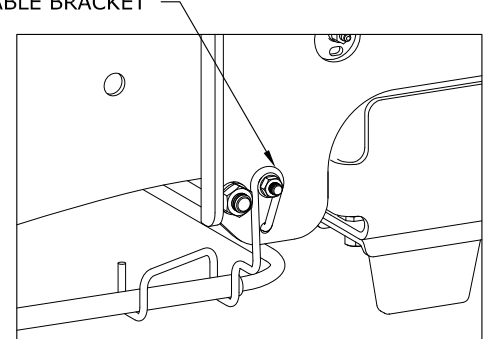

FIGURE 4.6: Cable Bracket

STEP 5:

Tighten all hardware in this order:

- 1) Tighten all center section hardware to 80 ft. lbs.
- 2) Check to ensure that the hitch is square by measuring the space between the front cross member of the hitch and the bed cross member so that the space is equal on each side of the truck.
- 3) Tighten the U-bolts to 60ft. lbs.
- 4) Tighten the 5/8" X 7 1/2" hex cap screws to 60 ft. lbs.
- 5) Tighten the hardware that holds the side plates to the cross members to 80 ft. lbs.

STEP 6

INSTALL LATCH PIN RELEASE HANDLE

WARNING: LATCH PIN WILL NOT FUNCTION PROPERLY IF HANDLE IS NOT INSTALLED CORRECTLY.

Install the handle from underneath the truck by inserting it through the slot in the end of the center section toward the driver's side rear tire as shown, See Figure 6.1. Attach the handle to the latch pin as shown with the handle on the "cab side" of the square tab welded to the pin. The head of the bolt must be on the handle side, and the lock nut must be on the tab side. The tab is welded to the pin in an offset position so that the handle will be lined up over the center of the pin, See Figure 6.2 and 6.3. If the handle is fastened to the other side of the tab, the handle will not function properly. When installed correctly the latch pin may be disengaged from the ball by pulling on the handle from the driver's side wheel well and rotating the handle clockwise.

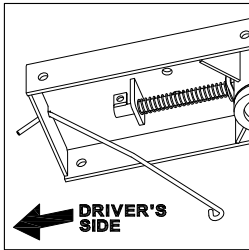

FIGURE 6.1: Center Section

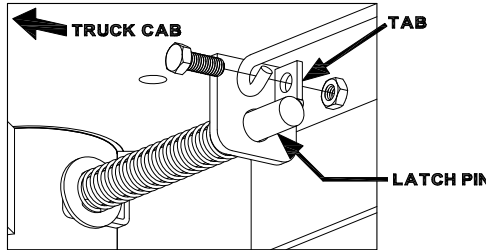

FIGURE 6.2: Handle installation

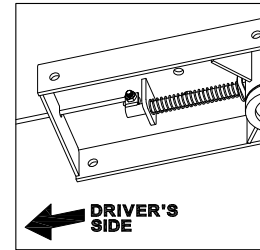

FIGURE 6.3: Completed Assembly

STEP 7:

To install the safety chain U-bolts it is necessary to drill four 1/2" holes through the truck bed floor. Drill the holes from beneath the truck, through the four holes located in the center section, See Figure 7.1. Drop a U-bolt through each pair of holes from the top side of the truck bed floor. Place a conical spring and lock nut on each of the four legs. Tighten the lock nuts until flush with the bottom of the U-Bolts, See Figure 7.2.

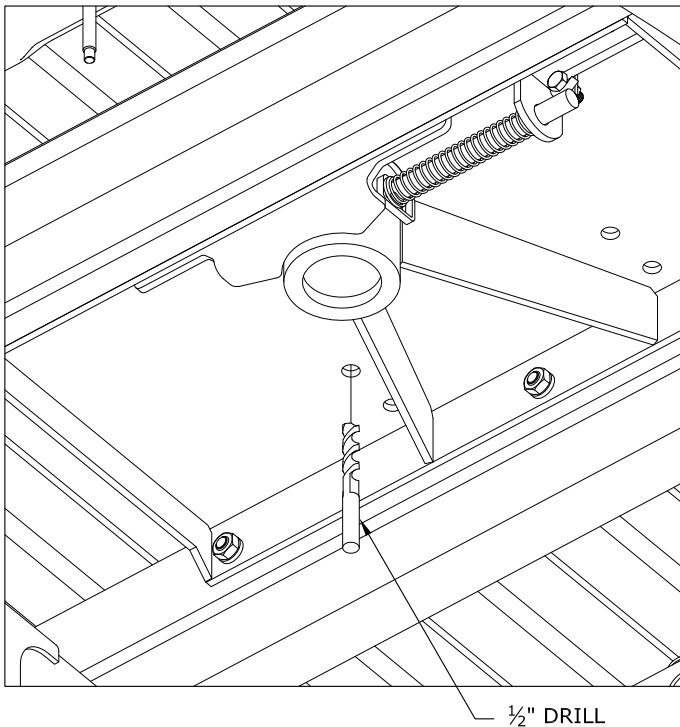

FIGURE 7.1: View from under the bed

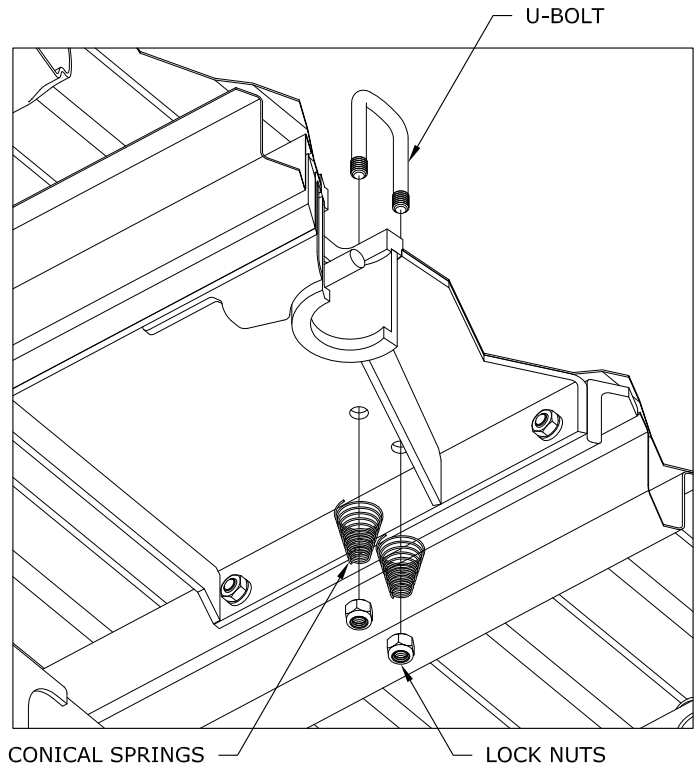

FIGURE 7.2: Cut away view from under the bed.