

<THESE INSTRUCTIONS MUST BE GIVEN TO THE END USER>



B&W Trailer Hitches
1216 Hawaii Rd / PO Box 186
Humboldt, KS 66748
P:800.248.6564
F:620.869.9031 See Limited Lifetime Warranty at bwtrailerhitches.com/warranty

*Call or Email us for
Installation Support*
hitches@turnoverball.com
bwtrailerhitches.com

Receiver Hitch Installation Instructions

MODEL RH670118,
RH670118BW

2018 - 2024 Toyota Rav 4

MAXIMUM TOW RATING (GTW): 4500 LBS
MAXIMUM TONGUE WEIGHT (VTW): 675 LBS

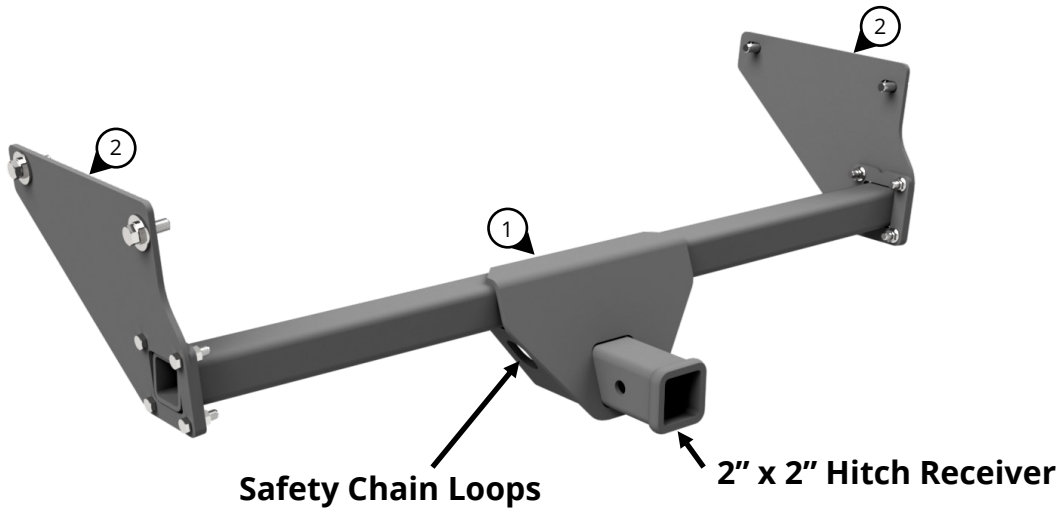

BOX: RH670118		
#	DESCRIPTION	QTY
1	Hitch Frame	1
2	Side Plate	2

BOLT BAG: 2110-670118-00		
DESCRIPTION	QTY	
M12 x 35mm Cap Screw	4	
3/8" x 1-1/4" Cap Screw	8	
3/8" Flange Nut	8	
1/2" Conical Washer	4	

IMPORTANT SAFETY NOTICE FOR HITCH INSTALLERS AND CUSTOMERS.

Read all installation and operating instructions along with all labels before installing or using this product.

⚠️ WARNING

Failure to comply with the safety information in these instructions could result in serious injury or death.

- ⚠️** Do not modify this product in any manner. Doing so could alter its integrity and lead to a loss of attachment between the trailer and the tow vehicle.
- ⚠️** Adding components to the chassis of any vehicle can be hazardous. There is potential for unexpected combustion of fuel, electric shock, burns, shifting or falling of unstable vehicle, damage to vehicle, injury from tool usage and many other hazards. This installation must be completed by someone who is aware of the hazards involved. This person must be knowledgeable of proper safety procedures for a vehicle modification of this nature, and for usage of the equipment required to perform the installation.
- ⚠️** Do not exceed tow or tongue rating of coupler, tow or tongue rating of hitch, or tow or weight ratings of tow vehicle or trailer. See vehicle and trailer manufacturer information for ratings. Exceeding these ratings may cause damage to towing components or loss of attachment between the trailer and vehicle.
- ⚠️** This product was designed to fit vehicles in their original, "as manufactured" condition. Compatibility with vehicles having replacement parts, or other modifications is not guaranteed. Inspect vehicle for modifications before installation of this product.
- ⚠️** A visual inspection of the towing components should be performed before each use. Regularly check that all connections are secure, including those that secure the hitch to the vehicle. Check for cracks or damage to the hitch, tow vehicle receiver, trailer coupler and frame. Do not use the hitch if cracks or damage outside of normal wear is found. Using a hitch that has unsecure connections and/or cracks or damage could result in damage to the tow vehicle, trailer, towing components and loss of attachment between the tow vehicle and trailer.
- ⚠️** Without proper knowledge, towing can be a dangerous activity. Understand all the risks involved with towing before proceeding. For information on towing safety, see **"The Trailer Handbook: A Guide to Understanding Trailer and Towing Safety"** from the National Association of Trailer Manufacturers, www.NATM.com and your trailer and tow vehicle manufacturer's owner's manual.
- ⚠️** Always use safety chains while towing. Crossing the safety chains under the tongue of trailer may prevent some damage to the trailer if detachment occurs.

NOTE: Use the parts list on the front page to verify that all parts and hardware are present.

TOOLS REQUIRED

- 9/16" open end wrench
- 9/16" & 19mm sockets
- Impact wrench or ratchet
- Torque wrench
- Safety glasses
- Flashlight

PREPARE TO INSTALL



19mm
SOCKET

1. Under the rear of the vehicle, locate and remove the two plastic covers from each side of the vehicle, as shown in Figure A1.
2. Using the provided M12 bolts, screw a bolt into each hole. This will help ensure that there are no obstructions in the hole. If the bolt will not easily thread into the holes, clean the threads with an M12 -1.25 thread chaser.



FIGURE A1: VIEW OF THE REAR FRAME UNDER THE VEHICLE

INSTALL SIDE PLATES



19mm
SOCKET

3. Through the uncovered threaded holes, loosely attach each side plate to the frame with two M12 cap screws and 1/2" conical washers, see Figure B1.

NOTE: Install the conical washers so the teeth are placed against the side plate.

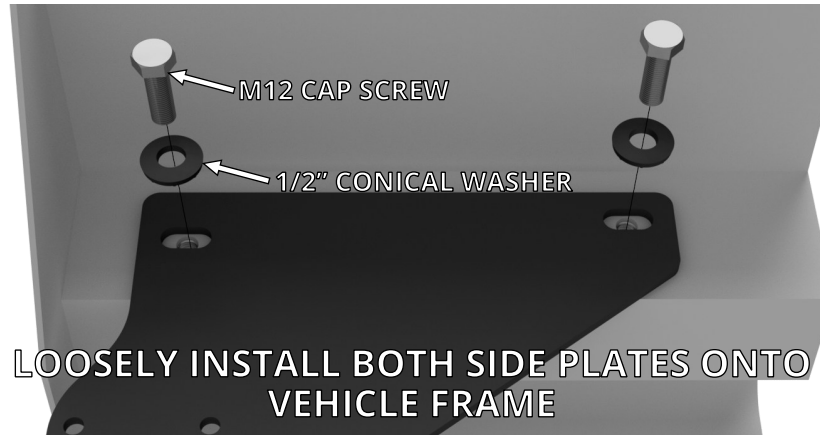
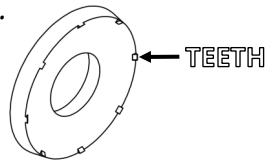

FIGURE B1: SIDE PLATE INSTALLATION

INSTALL HITCH FRAME



9/16"
SOCKET



9/16" OPEN END
WRENCH

4. Retrieve the hitch frame. Raise the frame between the side plates, as shown in Figure B2. Attach the frame to the side plates using eight 3/8" x 1-1/4" bolts and 3/8" flange nuts.
5. Tighten all the bolts, then torque the M12 bolts to 85 ft.-lbs. Next, torque the 3/8" bolts and nuts to 45 ft.-lbs.

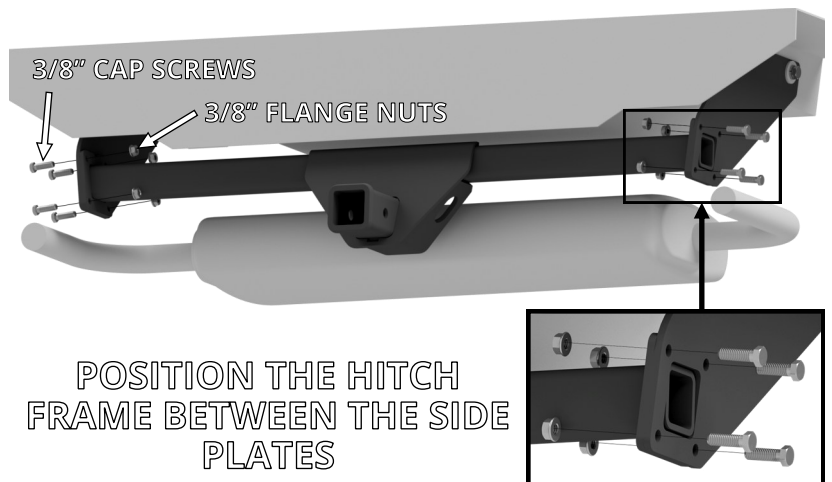

FIGURE B2: RECEIVER FRAME INSTALLATION