

<THESE INSTRUCTIONS MUST BE GIVEN TO THE END USER>



B&W Trailer Hitches
 1216 Hawaii Rd / PO Box 186
 Humboldt, KS 66748
 P:800.248.6564
 F:620.869.9031

See Limited Lifetime Warranty at
turnoverball.com/warranty

Call or Email us for
 Installation Support
hitches@turnoverball.com
www.bwtrailerhitches.com

Installation Instructions

PUCP7543

PUCP7543BA

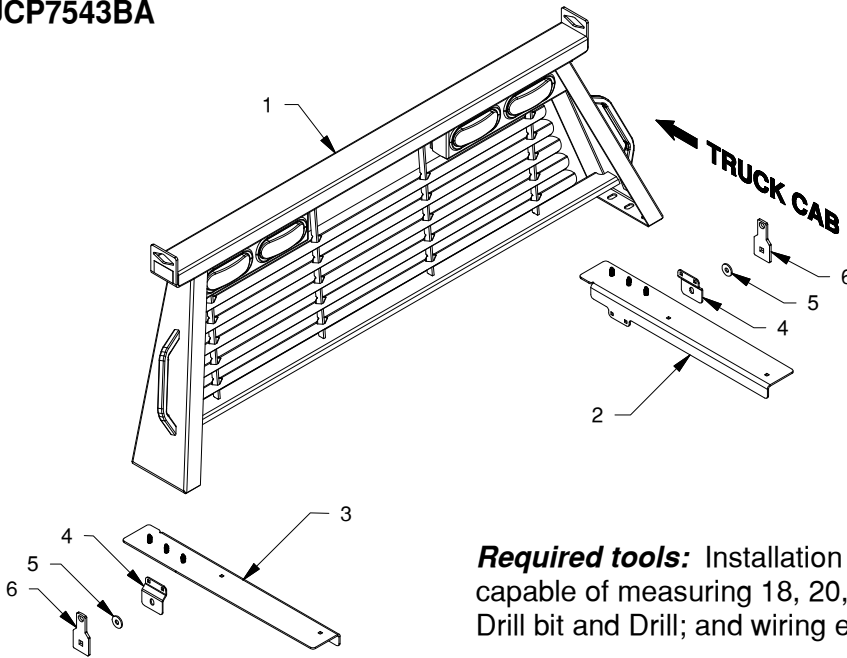

CAB PROTECTOR PARTS LIST		
ITEM	DESCRIPTION	QTY
1	Cab Protector	1
2	Passenger Side Bed Protector	1
3	Driver Side Bed Protector	1
4	Bed Protector Extension Bracket	2
5	Bed Protector Mounting Spacer	2
6	Bed Protector Mounting Bracket	2

HARDWARE KIT		
DESCRIPTION	QTY	
5/16" X 1-1/2" Carriage Bolts	4	
5/16" Flat Washers	4	
5/16" Lock Washers	4	
5/16" Finish Nuts	4	
5/16" X 3/4" Carriage Bolts	4	
5/16" Flange Nuts	4	
3/8" Large Flat Washers	6	
3/8" Lock Washers	6	
3/8" Finish Nuts	6	
1/2" X 1-1/4" Carriage Bolts	2	
1/2" Flat Washers	2	
1/2" Lock Washers	2	
1/2" Finish Nut	2	
1/2" Bolt Retainer	4	

Required tools: Installation of the cab protector requires a torque wrench capable of measuring 18, 20, & 80 ft-lbs; 1/2", 9/16", & 3/4" Sockets; a 5/16" Drill bit and Drill; and wiring equipment.

⚠️ WARNING

Failure to comply with the safety information in these instructions could result in serious injury or death.

- ⚠️ Read all installation and operating instructions along with all labels before using this product.
- ⚠️ Do not modify this product in any manner. Doing so could alter its integrity and lead to a loss of attachment between the cab protector and truck.
- ⚠️ This installation must be completed by someone who is aware of the hazards involved. This person must be knowledgeable of proper safety procedures for a vehicle modification of this nature, and for usage of the equipment required to perform the installation.

PREPARE FOR INSTALLATION

- Verify proper fit of cab protector.** Place the bed protectors on the pickup sides as shown in Figure A1. Make sure the bed protector flange is pushed tightly against the front of the bed and the inside of the bed sides. Measure across the truck from the center of the middle threaded stud on the driver side to the center of the middle stud on the passenger side. Next, measure the distance between the two middle mounting slots on each side of the cab protector. The two measurements should be within 1/2" of each other.

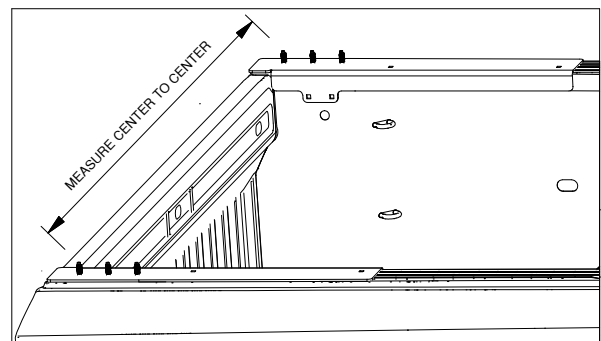

Figure A1: View looking at front of bed.

INSTALL MOUNTING BRACKETS

- 1. Remove plastic bed covers.** Installation of the mounting hardware for the bed protectors require access to the forward stake pockets. Remove both plastic bed covers. Each cover is secured with plastic "clips" and can be detached by pulling up on the plastic, see Figure B1. Keep each cover to replace after the mounting hardware is installed.

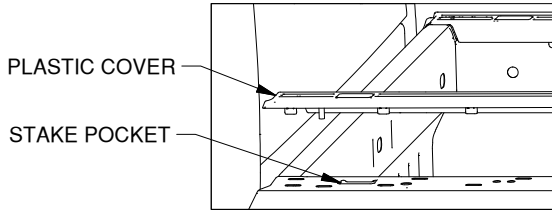

Figure B1: View looking at back of cab.

- 2. Install mounting brackets.** Locate the two bed protector mounting brackets and spacers. Install a 1/2" x 1-1/4" carriage bolt into each bracket and secure using a 1/2" bolt retainer, see Figure B2. Each bracket will be positioned inside the forward stake pockets so the 1/2" carriage bolt will stick out of the round hole at the bottom of each pocket, see Figure B3. Secure the 1/2" carriage bolt onto the bed with a mounting spacer and a 1/2" bolt retainer as shown in Figure B4.

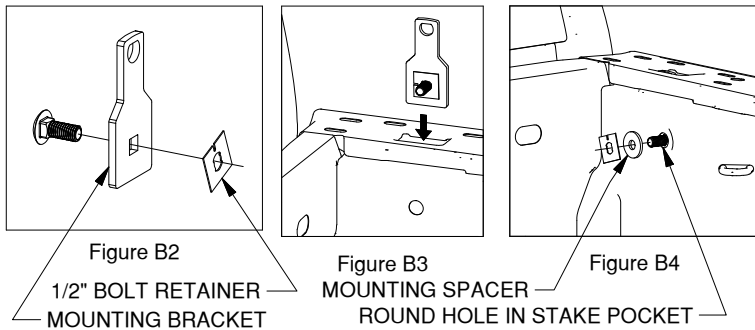

Figure B2

Figure B3

Figure B4

1/2" BOLT RETAINER
MOUNTING BRACKET

MOUNTING SPACER
ROUND HOLE IN STAKE POCKET

- 3. Finish installing mounting brackets.** Repeat installation of the mounting bracket on the other side of the truck. When both 1/2" carriage bolts are in place and secure **replace the plastic bed covers.**

INSTALL BED PROTECTORS

- 1. Assemble bed protectors.** Locate the bed protector extension brackets and the passenger and driver side bed protectors. Attach an extension bracket to each bed protector with two 5/16" x 3/4" carriage bolts and flange nuts, as shown in Figure C1. Tighten each nut.
- 2. Mount bed protectors.** Place the bed protectors back onto the pickup bed rail and pass the 1/2" carriage bolt mounted into the bed into the extension bracket added to each bed protector. Secure the 1/2" carriage bolt with a 1/2" flat washer, lock washer, and finish nut, see Figure C2. Push the bed protectors towards the cab so they are firmly against the front of the bed. Tighten each 1/2" finish nut to 80 ft-lbs.

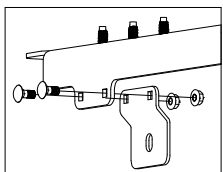

Figure C1

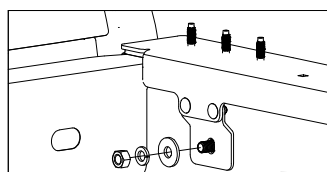

Figure C2: View looking at passenger side bed rail.

- 3. Drill the hole locations.** Check under the bed rail in the area of each of the square holes in the bed protectors. Make sure there are no lights, wires, or other obstructions. Push each bed protector against the inside of the truck bed sides. Using the square holes as a pilot, drill through the truck bed rails using a 5/16" drill bit.
- 4. Install the carriage bolts.** Insert a 5/16" x 1-1/2" carriage bolt in each of the drilled holes and secure using a flat washer, lock washer, and finish nut, see Figure C3. Tighten each nut to 18 ft-lbs.

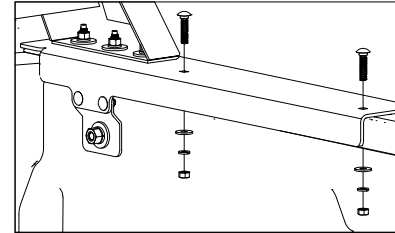

Figure C3: View looking at passenger side bed rail.

INSTALL CAB PROTECTOR

- ⚠ WARNING:** Components of the cab protector are heavy and cumbersome to handle. Failure to use proper lifting techniques and an adequate amount of people when moving and handling the cab protector could result in property damage or serious injury.

- 1. Mount cab protector.** Position the slots on the bottom of the cab protector over threaded studs on the bed protectors, see Figure D1. Fasten the cab protector with the provided 3/8" Large flat washers, lock washers, and finish nuts. Before fully tightening, make sure the cab protector is centered with the truck as viewed from the rear. Then tighten the 6 nuts on the cab protector to 20 ft-lbs. Do not overtighten.

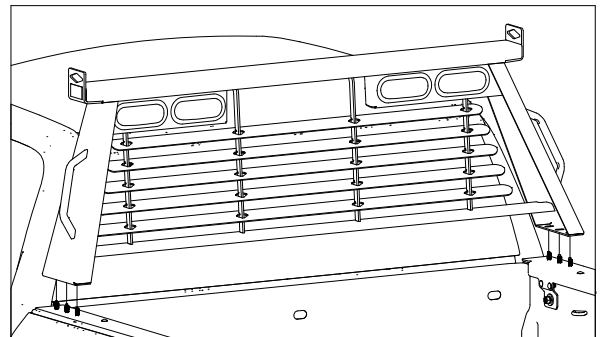

Figure D1: View looking at cab of truck.

- 2. Install wiring.** Splice the tail of the cab protector wiring harness into the vehicle's wiring. The Green wire is for the passenger side turning signal and braking. The Yellow wire is for the driver side turning signal and braking. The Brown wire is for clearance. The White wire is for ground. Remove excess wire so that there is not any loose wiring. Be sure that wiring is protected from sharp edges or other obstacles that could damage the wires. When installed correctly the two outside lights will function as brake, turn, and tail lights while the inside two lights will only function as tail lights.